



## HP iSCSI storage solution guide

How companies of all sizes benefit from iSCSI-based storage



Data growth rates are increasing by 50 per cent or more every single year. Governance and regulatory requirements are becoming more numerous and complex. Users are expecting nothing short of 24x7 access to information.

Improving the efficiency of your storage infrastructure is imperative – not only to accommodate these demands but also to drive down costs in a difficult economy. To this end, businesses of all sizes are embracing iSCSI (Internet SCSI) storage area networks (SANs). In the quest to control costs and to boost the efficiency of IT operations, IT managers are looking more closely at iSCSI SANs and how these can benefit their overall IT infrastructure.

### How can this iSCSI storage solution guide help?

Use this guide to better understand the benefits of iSCSI SAN solutions and how they can fit in different environments. In addition to demystifying iSCSI SANs, this guide provides several informative iSCSI use cases and practical deployment examples.

### Part 1: The case for iSCSI SAN technology (page 2)

- Accommodate storage in a virtualised environment with iSCSI technology
- View your storage and IT infrastructure holistically

### Part 2: Demystifying iSCSI (page 3)

### Part 3: Use cases (pages 4 – 7)

- Unified storage for small and mid-sized environments: HP X1000 Network Storage Systems
- Storage expansion for x86 servers: HP MSA2000i G2
- Enterprise functionality that enhances virtual environments: HP LeftHand P4000 SANs
- iSCSI gateways – using iSCSI and Fibre Channel together

### Part 4: Choosing the right HP iSCSI solution (page 8)

## Part 1: The case for iSCSI SAN technology

Traditionally, many businesses have accommodated the exponential growth of data by adding more servers or direct attached storage (DAS). DAS, however, creates 'islands' of storage, leads to underutilisation of resources and must often be managed using multiple dissimilar interfaces. The DAS approach does not scale well, and the continued use of DAS is a source of extra headaches – creating an environment that is inefficient, expensive and difficult to protect.

So what's the alternative? A dedicated storage solution that connects servers and storage via a SAN can vastly simplify management and enable better resource utilisation.

Most large companies have traditionally deployed Fibre Channel SANs for their low-latency and high-performance characteristics. Fibre Channel SANs, however, require a specialised network, which can add to cost and overhead. The added cost and learning curve have spurred the emergence and broad acceptance of iSCSI – or IP – SANs. In an iSCSI SAN, the communication between a server application and the physical hard disk drive is transported over a TCP/IP Ethernet network – the same network technology used today by the vast majority of all organisations.

iSCSI enables small and medium businesses to deploy SAN technology that was previously deemed out of reach. It allows large organisations to create complementary storage tiers for secondary servers or expand their existing networked storage to include workgroups or departments. It enables the consolidation of storage for increased capacity and utilisation and as a complement to network attached storage (NAS).

### **Accommodate storage in a virtualised environment with iSCSI technology**

Server virtualisation projects, in particular, trigger discussions about iSCSI SANs. Virtualised workloads typically include Web applications, infrastructure services, SQL Server, or e-mail.

The ability to move virtual machines (VMs) freely between physical servers is essential to achieve load-balancing, high-availability (HA) and disaster-recovery (DR) capabilities.

iSCSI SANs can help ease common issues encountered in virtualisation deployments, such as managing relationships between VMs and storage, data protection and storage management, and VM mobility.

### **View your storage and IT infrastructure holistically**

Storage should be viewed as an integral component of, instead of an attachment to, your IT system. Even a well-designed IT environment can come to a partial halt if NICs, network components, servers, storage assets and the software stacks in all of these elements have not been tested for compatibility. Choosing an IT provider that offers a wide range of the above components will help ensure compatibility. Plus, it is much easier to resolve storage and IT issues when working with one vendor instead of many.

## Part 2: Demystifying iSCSI – performance, manageability and security

Several common misperceptions have persisted about iSCSI vs traditional Fibre Channel deployments. With iSCSI becoming a mainstream technology and large vendors like HP or IBM offering iSCSI products, these notions are no longer necessarily true.

**Performance** – Some casual observers believe that iSCSI lacks the performance required for enterprise applications. The truth is that you can easily ensure that performance and service-level expectations are met with iSCSI by running your storage traffic over an Ethernet network that is physically or logically separate from your primary LAN. For those who look at bandwidth and assume a 4 Gb/s Fibre Channel implementation is four times faster than a 1 Gb/s iSCSI implementation, you should also consider the fact that key applications have random I/O patterns. Performance bottlenecks, therefore, have more to do with the time it takes to write and read data from hard disk drives than with network bandwidth. Performance validation tests on a 100 TB iSCSI SAN, conducted as early as 2007, showed a 15-node configuration (replicated across two sites) that exceeded the maximum random input/output operations per second (IOPS) of most high-end Fibre Channel SANs on the market at the time. And with the proliferation of 10 Gb/s Ethernet networks, iSCSI implementations have significant performance headroom.

**Myth:** *iSCSI introduces more traffic over corporate LANs, which are already overburdened with network traffic.*

**Reality:** The intent of SCSI over TCP/IP is to run storage traffic on high-performance switched Ethernet networks. Running storage traffic on an Ethernet network physically or logically separate from the primary LAN network will help you meet performance and service-level requirements.

**Manageability** – Fibre Channel is perceived by some as being easier than iSCSI to manage. When you consider network-independent tasks, there is actually very little difference in manageability between the two technologies. The iSCSI network is if anything probably easier to manage because most IT administrators are more familiar with Ethernet than with Fibre Channel.

**Myth:** *iSCSI SANs can be run on the same Ethernet backbone as other traffic.*

**Reality:** While this is technically true, you should avoid doing so for security reasons. It is best to implement iSCSI storage on a separate Ethernet network. You will still incur lower costs compared to Fibre Channel (from HBA, FC cables and FC switches to FC arrays and software), because your IT staff is working with similar protocols and management tools across data and storage backbones.

**Network security** – Finally, some believe that iSCSI SANs lack the security of Fibre Channel SANs. If you separate your iSCSI network logically or physically using an industry-standard Gigabit Ethernet switch or a virtual LAN (VLAN), your iSCSI network is just as secure as Fibre Channel. It is also less costly, when you consider the HBAs, cables, switches, arrays and software associated with Fibre Channel technology.

## Part 3: Use cases

### Unified storage for small and mid-sized environments: HP X1000 Network Storage Systems

HP X1000 Network Storage Systems are designed to help IT generalists deploy network storage without needing significant storage expertise. These Windows®-powered shared storage solutions can be used as both an iSCSI target (i.e., storage device) and an optimised file server (NAS) – providing simple, cost-effective centralised storage for end-user file sharing and shared storage for application servers. The X1000 is especially easy to install and manage.

### Scenario

A mid-sized professional services company initially had eight servers spread across three locations. Rapid data growth led IT managers to add more servers and direct attached storage – but then they found themselves spending too much time managing individual ‘islands’ of storage. They were hesitant to move to network storage because they feared they did not have the resources to deploy a better solution.

Once they had looked at the HP X1000 Network Storage Systems family, however, they realised that the X1600 model could not only provide them with the centralised capacity they needed, but could also be used as a file server and disk-based backup target. Because it is built on HP ProLiant technology and uses the Windows Storage Server operating system, the X1600 was easy to integrate into their existing environment. And it offered future investment protection: as they look to add emerging technologies such as virtualisation, they could use their X1600 as a VMware repository and even replicate data from one model in the X1000 Network Storage System family to another, using HP StorageWorks Storage Mirroring Software.

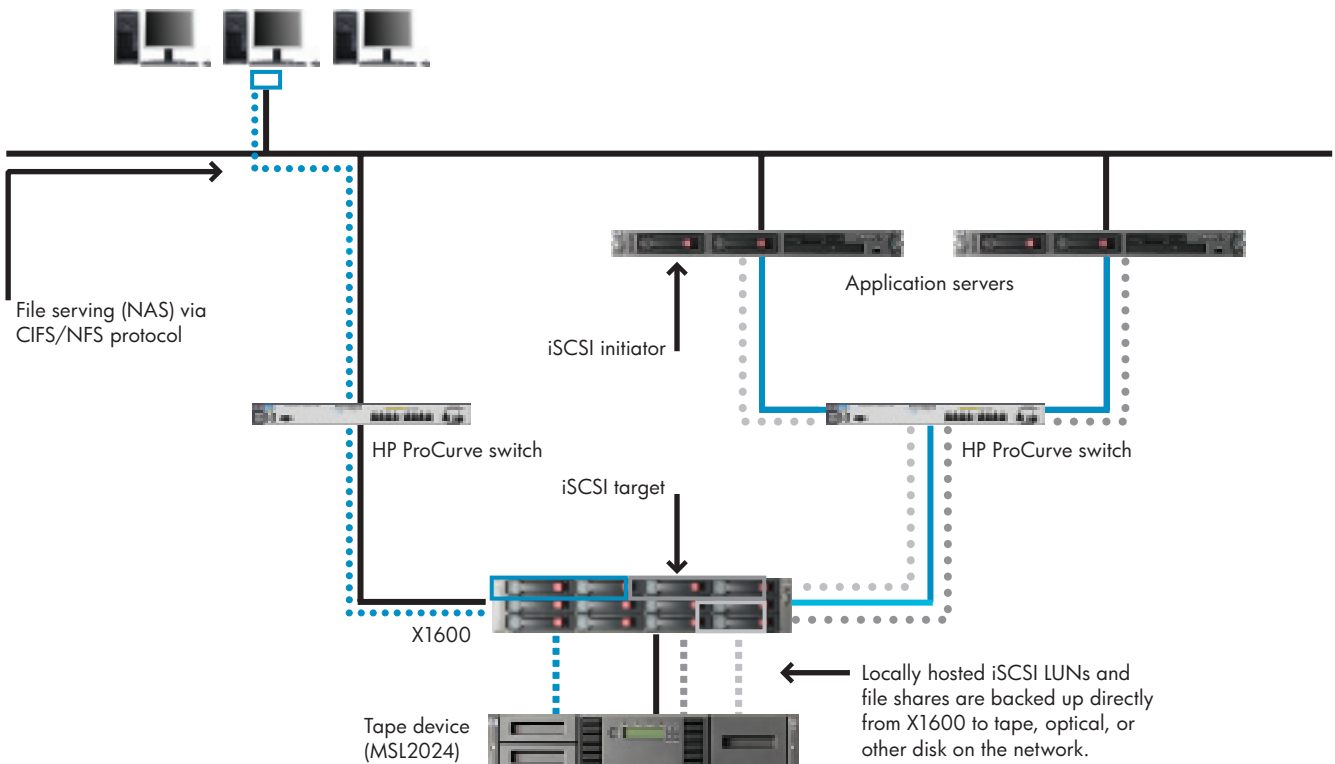

### Storage expansion for x86 servers: MSA2000i G2

The HP StorageWorks 2000i G2 Modular Smart Array (MSA2000i G2) features the very latest in efficient consolidation, functionality and technology at very affordable prices. It is ideal for businesses needing to consolidate their storage, including smaller companies with tight budgets and limited IT expertise, or larger companies that have perhaps hundreds of smaller departments and remote locations. The modular design lets you grow as your storage demands increase. These systems can scale and perform well at higher workloads. All models support the optional HP StorageWorks 2000 Modular Smart Array Snapshot Software, which offers controller-based snapshot and cloning functionality.

### Scenario

A retail company had initially set up a direct attached storage system that adequately satisfied their original storage requirements. With rapid data growth, however, this became costly and difficult to manage as the number of servers continued to increase. The move to an MSA2000i G2-based SAN allowed them to reduce costs and management efforts by centralising storage across their servers. Because the MSA2000i G2 is designed to grow with their business – enabling them to grow their storage as their needs grow – it is an investment they can trust.

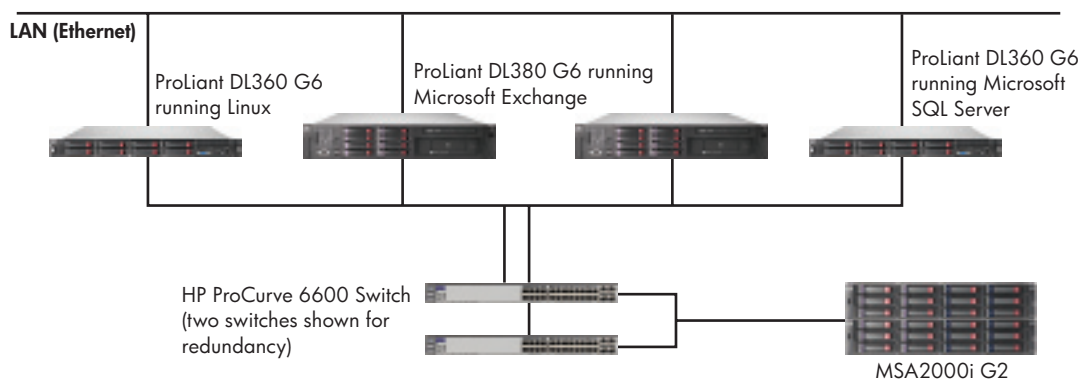

### Enterprise functionality that enhances virtual environments: HP LeftHand P4000 SANs

Server virtualisation software has brought great relief to IT organisations searching for high-availability (HA) and disaster-recovery (DR) solutions with a low cost of entry. Regrettably, the same organisations choosing server virtualisation as part of their HA and DR strategy often overlook the requirement for a shared storage solution capable of supporting the HA and DR features that server virtualisation offers. Fortunately, HP LeftHand P4000 SAN Solutions provide cost-effective support for server virtualisation and offer integrated, all-inclusive HA and DR solutions for storage that are seen as superior to those offered at extra cost by other SAN vendors.

### Scenario

A utility company deployed server virtualisation for two dozen application (Exchange, SharePoint) and Web servers at its headquarters site, which has data centres in two separate buildings and two remote sites. It chose HP LeftHand P4000 SAN Solution as the matching storage infrastructure. The HP LeftHand P4500 Multi-Site SAN provides IT administrators with flexible and dynamic shared storage. Built-in HA features maximise application availability as volumes remain on line in the event of a building failure at headquarters. Straightforward SAN management and thin provisioning help keep costs at a minimum. HP LeftHand P4000 Replication for Remote Offices Software replicates remote site data to the headquarters data centres for disaster recovery.

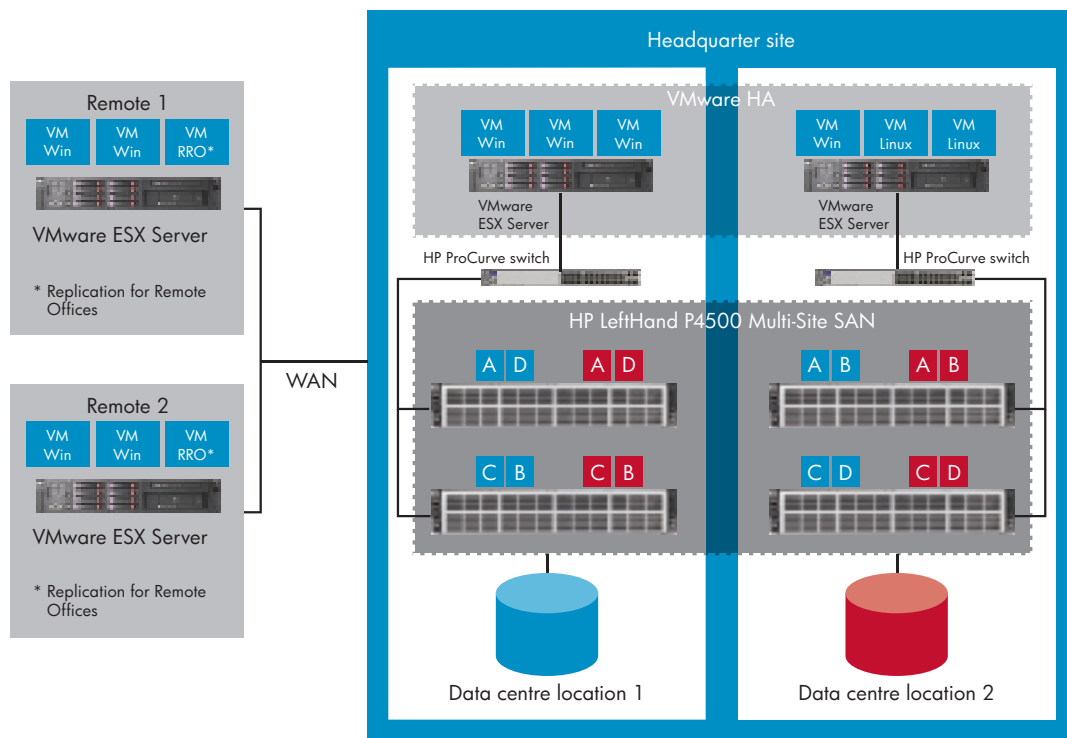

## iSCSI gateways – using iSCSI and Fibre Channel together

As businesses grow, so does the amount of information that must be managed, shared and protected. Rapid growth may increase the cost of operations and spread critical business data and resources across multiple systems and applications. Adding HP StorageWorks X3000 Network Storage Gateways to a Fibre Channel SAN/array or SAS array – or adding an HP StorageWorks MPX200 Multifunction Router to an HP StorageWorks Enterprise Virtual Array (EVA) – extends your SAN/array investment with integrated multiprotocol support, letting you incorporate iSCSI servers without requiring additional storage arrays or management costs.

HP iSCSI gateways offer simultaneous iSCSI and Fibre Channel support, providing modular multiprotocol SAN designs with increased scalability, stability and ROI on storage infrastructure. Drawing on IP networks, iSCSI gateways can extend Fibre Channel SAN advantages into smaller departments and remote locations, where budget constraints

would not allow for a dedicated Fibre Channel SAN. They enable storage consolidation by allowing the creation of larger SANs that extend over longer distances and by providing access to storage that can be scaled or re-allocated when needed.

### Scenario

A large manufacturing company started seeing a proliferation of servers across departments. While the company already had a SAN, based on HP StorageWorks EVAs, it was being used only for corporate e-mail and database applications. Managing the storage and backup for all the departmental servers was becoming complex and time-consuming. After evaluating the new MPX200 Multifunction Router, the IT manager decided to bring the MPX200 in and use it to consolidate the storage for all the departmental servers. With the MPX200, the company was able to provide simple low-cost IP access to the EVA SAN for the departmental servers. As a result, they have been able to consolidate backups and provide more capacity – and higher service levels – for the departmental server applications.

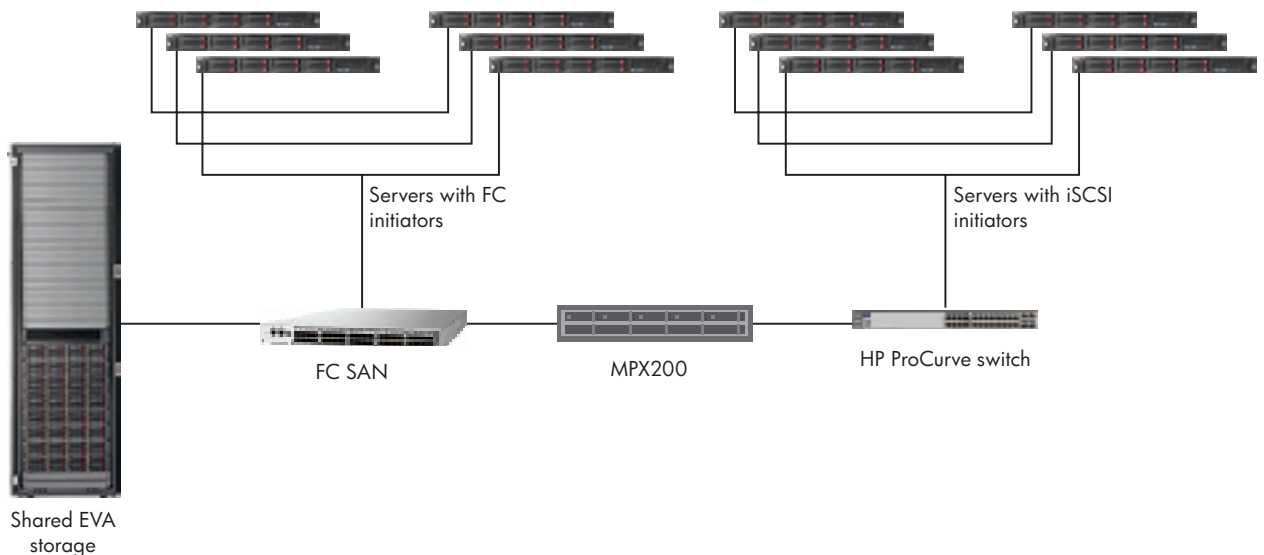

## Part 4: Choosing the right HP iSCSI solution

HP's simple, affordable and reliable iSCSI storage solutions can play an important role in your data storage strategy when you consider iSCSI technology as a cost-effective, easy-to-manage alternative to Fibre Channel networks.

### Which HP iSCSI solution is right for you?

- If you are consolidating storage for a few servers and do not need a high-availability solution, you should consider X1000 Network Storage Systems, which provide unified iSCSI SAN and file-serving capabilities.
- If you need a solution with higher availability and the ability to clone storage areas, consider the HP MSA2000i G2, which offers dual controllers and writable snapshot functionality.
- If your requirements call for high availability, disaster recovery, or integration with virtual environments, HP LeftHand P4000 SANs offer these capabilities plus the freedom to grow performance and capacity in near-linear fashion.
- If you need a mix of iSCSI and Fibre Channel, consider adding an X3000 Network Storage Gateway in front of your existing Fibre Channel SAN array or utilising the MPX200 Multifunction Router for the HP StorageWorks EVA.
- When considering iSCSI storage solutions, keep HP ProCurve in mind: the full line of switching solutions are tuned for iSCSI deployments. The 2910 series is a great choice for small to mid-size iSCSI network deployments – while the 6600 series provides advanced functionality and scalability.

### Why HP?

At HP, we test all of our disk storage systems thoroughly to verify optimal performance. In addition to iSCSI storage products, we offer a full range of multifunction network adaptors, which support hardware-based iSCSI acceleration to improve performance. And, when paired with HP StorageWorks iSCSI arrays, they deliver an end-to-end iSCSI solution.

## HP Services

### Put the technical know-how of HP Services experts to work for you

When you buy HP iSCSI storage solutions, you can trust the service professionals at HP to collaborate with you to make technology the difference in your business.

### Recommended services

- HP Support Plus 24 Service – for around-the-clock, reactive on-site hardware support and over-the-phone software support
- HP Installation and Startup for HP storage solutions – fast, reliable start-up for enhanced server virtualisation and business continuance with SAN solutions

### Related services

- HP Proactive 24 Service – integrated proactive and reactive services for businesses looking to achieve better performance, higher availability and greater stability
- HP Proactive Select Service – improved IT performance and manageability for businesses looking for services flexible enough to cover the IT product life-cycle and adapt to changing needs

For additional information about storage-related services from HP, contact your HP sales representative or HP-authorized Channel Partner, or visit: [www.hp.com/hps/storage](http://www.hp.com/hps/storage)

## Customer technical training

Consider education as an integral part of your strategy to get the best return on investment for your HP storage solution. HP offers a range of training classes on storage software, networking, archival and disk storage systems. For more information on these services, please contact your HP representative or visit: [www.hp.com/learn/storage](http://www.hp.com/learn/storage)

## For more information

To learn more about HP iSCSI storage solutions, please contact your HP representative or HP Channel Partner, or visit: [www.hp.com/go/iSCSI](http://www.hp.com/go/iSCSI)

## Technology for better business outcomes

To learn more, visit [www.hp.com/go/iSCSI](http://www.hp.com/go/iSCSI)

© Copyright 2008, 2009 Hewlett-Packard Development Company, L.P. The information contained herein is subject to change without notice. The only warranties for HP products and services are set forth in the express warranty statements accompanying such products and services. Nothing herein should be construed as constituting an additional warranty. HP shall not be liable for technical or editorial errors or omissions contained herein.

Windows is a U.S. registered trademark of Microsoft Corporation.

4AA1-9151EEW Rev. 1, May 2009

